

which has never been since surpassed. Dr. Schonland expressed disappointment that the membership in recent years has been but a little more than a thousand, for South Africa has expanded enormously since 1906 and with this expansion the need for, and potential value of, such a body as the Association. The general aims of the Association have not changed at all with the passing of years: "We exist," he said, "primarily to create and foster a scientific fraternity in South Africa, not to publish original work. We exist to provide a common meeting-ground for South African scientists and a forum for general discussion of the problems of this country from the scientific angle." He defended the use of Afrikaans by those who preferred it, for "we were intended by our founders to be parochial, and we should pride ourselves on being parochial. I would suggest that if we try to be anything else we will have mistaken our real aim".

Having thus firmly and, most people would agree, wisely placed the Association in its proper perspective, Dr. Schonland went on to make some concrete suggestions. The *South African Journal of Science* should have a series of semi-popular articles reviewing and surveying the new ideas of science and so bridge the gap between those who teach and do advanced research work and those who pay for it. This, he thought, is the proper function of the *Journal*, and it is but one aspect of the Association's duty, as representative of all sections of scientific opinion in South Africa, "to take a stronger, a more continuing and a more active interest in all scientific developments, national and university, in South Africa and to study carefully what is being done in other countries".

Besides his plea that the Association needs to form a standing committee to watch over scientific education in schools, Dr. Schonland suggested that the Association might consider taking a part in the formation of a body on the lines of the British Parliamentary and Scientific Committee and also help in the creation of better facilities for advanced research in South Africa. On this last-named point, he cited the instances of the National University in Canberra and the Institute for Advanced Studies in Dublin, but he made the interesting suggestion that a more acceptable solution might be the creation of a number of specialized institutes for advanced study, attached to and forming part of those universities which for one reason or another are best suited for them.

is required at all levels: at present it is wholly inadequate for future needs, while the practical content of general education is also inadequate for the needs of future citizens of a technological society. The cultural content of technical education is also generally inadequate; technical education requires special consideration, and training for adaptability is an outstanding requirement in an age of ultra-rapid technological change. The education of women and girls also demands particular attention in view of their dual role as workers and home-makers, and improved administrative arrangements are essential if education is to fulfil its true function in such a society.

The report does not suggest that all these propositions apply equally to every country, though the Conference considered that, so far as its knowledge extended, they are generally valid for the world as a whole. The stress is laid on the need for adapting technology to man, not man to technology. The questions formulated in this report—and which merit attention in current discussions on the expansion of both technical and technological education in Great Britain—are raised in the belief that mastery of the machine by man is not an end in itself: it is a means to the development of man and of the whole society.

The distinction between technician and technologist is not always kept clear in this report, particularly in the chapter on the content of technical education. Nevertheless, the report directs attention to some fundamental issues which no sound policy for either type of education can disregard. In both fields it must be recognized that we are concerned not simply with the efficiency of production, but also with the fundamental attitude which the men and women of to-morrow will adopt in facing the problems of a technological society. Both, too, in seeking to foster flexibility, must recognize that flexibility is determined not only by education and training but also by social, economic and technical conditions; and the administrative measures required to ensure that education becomes more adapted to the needs of a changing technological society are themselves likely to be most effective when they are informal and varied rather than concentrated and uniform. The administrator, no less than the teacher and student, has need of frequent opportunities of contact with the industrial world, and requires experience of the difficulties and problems created by technological development in society; just as the teacher and student should keep abreast of developments in research and of practical applications in industry.

BASIS OF TECHNICAL EDUCATION

GENERAL education to-day should be planned so as to enable the ordinary citizen to adapt himself to the needs of technological society and to understand what is happening and what is required of him. This was the theme of an international conference convened by the United Nations Educational, Cultural and Scientific Organization at Unesco House in June 1950*.

Broadly, the Conference found that organized social foresight is essential to enable the educational system of a country to prepare children for the type of life and work they are likely to encounter, and that a substantial development of technical education

* Education in a Technological Society: a Preliminary International Survey of the Nature and Efficacy of Technical Education. (Tensons and Technology Series.) Pp. 76. (Paris: Unesco; London: H.M.S.O., 1952.) 200 francs; 4s.; 75 cents.

GENETICAL IMPLICATIONS OF THE STRUCTURE OF DEOXYRIBONUCLEIC ACID

By J. D. WATSON and F. H. C. CRICK

Medical Research Council Unit for the Study of the Molecular Structure of Biological Systems, Cavendish Laboratory, Cambridge

THE importance of deoxyribonucleic acid (DNA) within living cells is undisputed. It is found in all dividing cells, largely if not entirely in the nucleus, where it is an essential constituent of the chromosomes. Many lines of evidence indicate that it is the carrier of a part of (if not all) the genetic specificity of the chromosomes and thus of the gene itself.

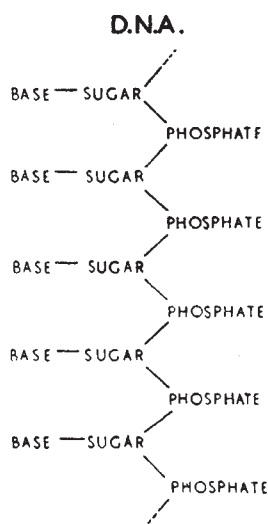

Fig. 1. Chemical formula of a single chain of deoxyribonucleic acid

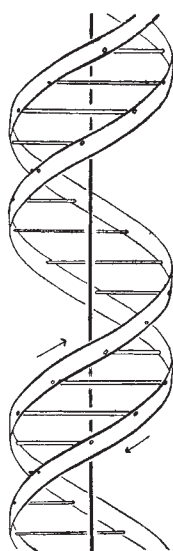

Fig. 2. This figure is purely diagrammatic. The two ribbons symbolize the two phosphate-sugar chains, and the horizontal rods the pairs of bases holding the chains together. The vertical line marks the fibre axis

a common fibre axis, as is shown diagrammatically in Fig. 2. It has often been assumed that since there was only one chain in the chemical formula there would only be one in the structural unit. However, the density, taken with the X-ray evidence², suggests very strongly that there are two.

The other biologically important feature is the manner in which the two chains are held together. This is done by hydrogen bonds between the bases, as shown schematically in Fig. 3. The bases are joined together in pairs, a single base from one chain being hydrogen-bonded to a single base from the other. The important point is that only certain pairs of bases will fit into the structure. One member of a pair must be a purine and the other a pyrimidine in order to bridge between the two chains. If a pair consisted of two purines, for example, there would not be room for it.

We believe that the bases will be present almost entirely in their most probable tautomeric forms. If this is true, the conditions for forming hydrogen bonds are more restrictive, and the only pairs of bases possible are :

adenine with thymine ;
guanine with cytosine.

Until now, however, no evidence has been presented to show how it might carry out the essential operation required of a genetic material, that of exact self-duplication.

We have recently proposed a structure¹ for the salt of deoxyribonucleic acid which, if correct, immediately suggests a mechanism for its self-duplication. X-ray evidence obtained by the workers at King's College, London², and presented at the same time, gives qualitative support to our structure and is incompatible with all previously proposed structures³. Though the structure will not be completely proved until a more extensive comparison has been made with the X-ray data, we now feel sufficient confidence in its general correctness to discuss its genetical implications. In doing so we are assuming that fibres of the salt of deoxyribonucleic acid are not artefacts arising in the method of preparation, since it has been shown by Wilkins and his co-workers that similar X-ray patterns are obtained from both the isolated fibres and certain intact biological materials such as sperm head and bacteriophage particles^{2,4}.

The chemical formula of deoxyribonucleic acid is now well established. The molecule is a very long chain, the backbone of which consists of a regular alternation of sugar and phosphate groups, as shown in Fig. 1. To each sugar is attached a nitrogenous base, which can be of four different types. (We have considered 5-methyl cytosine to be equivalent to cytosine, since either can fit equally well into our structure.) Two of the possible bases—adenine and guanine—are purines, and the other two—thymine and cytosine—are pyrimidines. So far as is known, the sequence of bases along the chain is irregular. The monomer unit, consisting of phosphate, sugar and base, is known as a nucleotide.

The first feature of our structure which is of biological interest is that it consists not of one chain, but of two. These two chains are both coiled around

The way in which these are joined together is shown in Figs. 4 and 5. A given pair can be either way round. Adenine, for example, can occur on either chain ; but when it does, its partner on the other chain must always be thymine.

This pairing is strongly supported by the recent analytical results⁵, which show that for all sources of deoxyribonucleic acid examined the amount of adenine is close to the amount of thymine, and the amount of guanine close to the amount of cytosine, although the cross-ratio (the ratio of adenine to guanine) can vary from one source to another. Indeed, if the sequence of bases on one chain is irregular, it is difficult to explain these analytical results except by the sort of pairing we have suggested.

The phosphate-sugar backbone of our model is completely regular, but any sequence of the pairs of bases can fit into the structure. It follows that in a long molecule many different permutations are possible, and it therefore seems likely that the precise sequence of the bases is the code which carries the genetical information. If the actual order of the

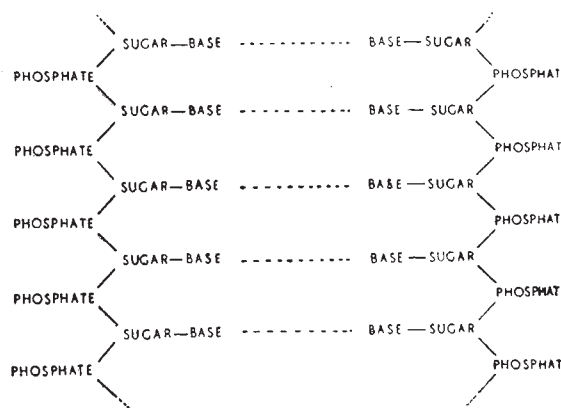

Fig. 3. Chemical formula of a pair of deoxyribonucleic acid chains. The hydrogen bonding is symbolized by dotted lines

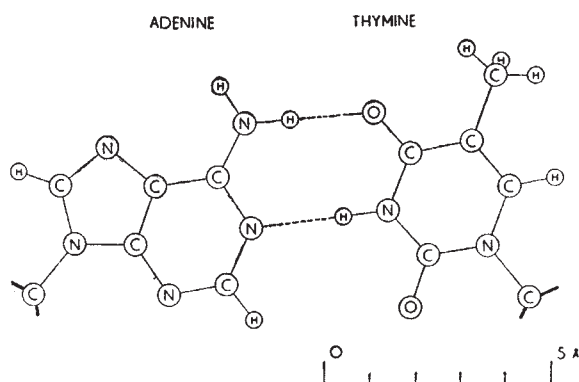

Fig. 4. Pairing of adenine and thymine. Hydrogen bonds are shown dotted. One carbon atom of each sugar is shown

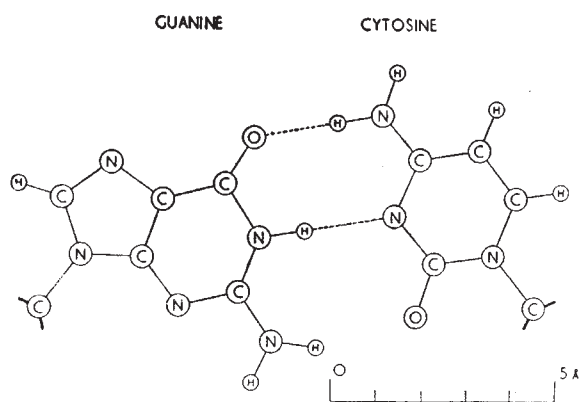

Fig. 5. Pairing of guanine and cytosine. Hydrogen bonds are shown dotted. One carbon atom of each sugar is shown

bases on one of the pair of chains were given, one could write down the exact order of the bases on the other one, because of the specific pairing. Thus one chain is, as it were, the complement of the other, and it is this feature which suggests how the deoxyribonucleic acid molecule might duplicate itself.

Previous discussions of self-duplication have usually involved the concept of a template, or mould. Either the template was supposed to copy itself directly or it was to produce a 'negative', which in its turn was to act as a template and produce the original 'positive' once again. In no case has it been explained in detail how it would do this in terms of atoms and molecules.

Now our model for deoxyribonucleic acid is, in effect, a pair of templates, each of which is complementary to the other. We imagine that prior to duplication the hydrogen bonds are broken, and the two chains unwind and separate. Each chain then acts as a template for the formation on to itself of a new companion chain, so that eventually we shall have two pairs of chains, where we only had one before. Moreover, the sequence of the pairs of bases will have been duplicated exactly.

A study of our model suggests that this duplication could be done most simply if the single chain (or the relevant portion of it) takes up the helical configuration. We imagine that at this stage in the life of the cell, free nucleotides, strictly polynucleotide precursors, are available in quantity. From time to time the base of a free nucleotide will join up by

hydrogen bonds to one of the bases on the chain already formed. We now postulate that the polymerization of these monomers to form a new chain is only possible if the resulting chain can form the proposed structure. This is plausible, because steric reasons would not allow nucleotides 'crystallized' on to the first chain to approach one another in such a way that they could be joined together into a new chain, unless they were those nucleotides which were necessary to form our structure. Whether a special enzyme is required to carry out the polymerization, or whether the single helical chain already formed acts effectively as an enzyme, remains to be seen.

Since the two chains in our model are intertwined, it is essential for them to untwist if they are to separate. As they make one complete turn around each other in 34 Å., there will be about 150 turns per million molecular weight, so that whatever the precise structure of the chromosome a considerable amount of uncoiling would be necessary. It is well known from microscopic observation that much coiling and uncoiling occurs during mitosis, and though this is on a much larger scale it probably reflects similar processes on a molecular level. Although it is difficult at the moment to see how these processes occur without everything getting tangled, we do not feel that this objection will be insuperable.

Our structure, as described¹, is an open one. There is room between the pair of polynucleotide chains (see Fig. 2) for a polypeptide chain to wind around the same helical axis. It may be significant that the distance between adjacent phosphorus atoms, 7.1 Å., is close to the repeat of a fully extended polypeptide chain. We think it probable that in the sperm head, and in artificial nucleoproteins, the polypeptide chain occupies this position. The relative weakness of the second layer-line in the published X-ray pictures^{3a,4} is crudely compatible with such an idea. The function of the protein might well be to control the coiling and uncoiling, to assist in holding a single polynucleotide chain in a helical configuration, or some other non-specific function.

Our model suggests possible explanations for a number of other phenomena. For example, spontaneous mutation may be due to a base occasionally occurring in one of its less likely tautomeric forms. Again, the pairing between homologous chromosomes at meiosis may depend on pairing between specific bases. We shall discuss these ideas in detail elsewhere.

For the moment, the general scheme we have proposed for the reproduction of deoxyribonucleic acid must be regarded as speculative. Even if it is correct, it is clear from what we have said that much remains to be discovered before the picture of genetic duplication can be described in detail. What are the polynucleotide precursors? What makes the pair of chains unwind and separate? What is the precise role of the protein? Is the chromosome one long pair of deoxyribonucleic acid chains, or does it consist of patches of the acid joined together by protein?

Despite these uncertainties we feel that our proposed structure for deoxyribonucleic acid may help to solve one of the fundamental biological problems—the molecular basis of the template needed for genetic replication. The hypothesis we are suggesting is that the template is the pattern of bases formed by one chain of the deoxyribonucleic acid and that the gene contains a complementary pair of such templates.

One of us (J.D.W.) has been aided by a fellowship from the National Foundation for Infantile Paralysis (U.S.A.).

¹ Watson, J. D., and Crick, F. H. C., *Nature*, **171**, 737 (1953).

² Wilkins, M. H. F., Stokes, A. R., and Wilson, H. R., *Nature*, **171**, 738 (1953). Franklin, R. E., and Gosling, R. G., *Nature*, **171**, 740 (1953).

³ (a) Astbury, W. T., Symp. No. 1 Soc. Exp. Biol., 66 (1947). (b) Furberg, S., *Acta Chem. Scand.*, **6**, 634 (1952). (c) Pauling, L., and Corey, R. B., *Nature*, **171**, 346 (1953); *Proc. U.S. Nat. Acad. Sci.*, **39**, 84 (1953). (d) Fraser, R. D. B. (in preparation).

⁴ Wilkins, M. H. F., and Randall, J. T., *Biochim. et Biophys. Acta*, **10**, 192 (1953).

⁵ Chargaff, E., for references see Zamenhof, S., Braverman, G., and Chargaff, E., *Biochim. et Biophys. Acta*, **9**, 402 (1952). Wyatt, G. R., *J. Gen. Physiol.*, **36**, 201 (1952).

GEOPHYSICAL AND METEOROLOGICAL CHANGES IN THE PERIOD JANUARY–APRIL 1949

IN a recent article¹ Lewis and McIntosh have considered the geophysical data for the period January–April 1949, which we presented in an earlier communication². On the basis of certain probability criteria they appear to show that the apparent regular variations in ionospheric and meteorological phenomena which occurred in that period were not significant. We have studied their article and made a separate statistical analysis of the *unsmoothed* data, and conclude that in all respects our original suggestions seem to be valid.

In our original article we presented graphs showing five-day moving averages in four parameters: (a) ground pressure, p ; (b) E -layer critical frequency, fE ; (c) F -layer critical frequency, $fF2$; and (d) K -index of geomagnetic activity. The connexion between ionospheric and geomagnetic phenomena is well known. Thus, Appleton and Ingram³ in 1935 established the correlation between geomagnetic activity and depressions in $fF2$. It is worthy of note that in the period under discussion the inverse correlation between K and $\Delta fF2$ is, as Lewis and McIntosh point out, considerably less striking than that between p and ΔfE (cf. Figs. 1 and 2 in our original article). It would seem, then, that if statistical analysis can be successfully applied to show that there is no significance between the variations in p and ΔfE , it is, *a fortiori*, evident that a similar analysis might, in the present instance, be used for discrediting the established relationship between K and $\Delta fF2$. Conversely, of course, the fact that a phenomenon appears to be statistically significant over a short period must likewise be treated with reserve. The need for the utmost care in the application and interpretation of statistical analyses to such a limited time series is thus clear.

From inspection of our graphs it seemed to us that, so far as p and ΔfE were concerned, the period was unusual in three respects: (i) there appeared to be four oscillations in ground pressure showing a progressive diminution of amplitude, with an average period of about 27 days; (ii) in like manner there appeared to be four marked oscillations of period about 27 days in ΔfE ; (iii) oscillations (i) and (ii) appeared to be almost exactly out of phase. In addition, we noted that the period was characterized by an unusual 27-day recurrence of great sudden commencement (S.C.) magnetic storms.

In our original communication we merely directed attention to these matters, and suggested that there

might be some connexion between them. We did not then suggest, nor do we now suggest, that from a period of length only four months any conclusions can be drawn regarding the general behaviour over a long period of any of the geophysical parameters considered. The severely limited number of observations available, together with the fact that there is considerable uncertainty about the correct statistical approach to time series analysis, seemed to us sufficient reason for not entering into an extended statistical analysis.

However, the contrary conclusions reached by Lewis and McIntosh (see below) have prompted us to re-examine the data. Briefly, their conclusions are: (i) the 27-day oscillation in ground pressure is of no significance, since the amplitude is no more than would be expected from mere chance observations; (ii) the 27-day oscillation in ΔfE is probably significant; (iii) oscillations (i) and (ii) are exactly in anti-phase; (iv) there is no significant correlation coefficient between the p and ΔfE data; (v) our conclusions arise from smoothing of the data.

We shall now outline our own analysis. In various communications⁴⁻⁶, Kendall has made it abundantly clear that most of the methods generally used for studying periodicities in time series (for example, periodograms, Fourier analysis, etc.) may yield very misleading results when applied to the kind of time series with which we are here concerned. He has also questioned the reliability of the usual significance tests for periodicities when applied in time series analysis. Kendall has shown that the most reliable approach is that of serial correlation coefficients as exhibited in the correlogram. He points out that although the correlogram may be insensitive, it does give a lower limit to the oscillatory effects, and that if it oscillates there is almost certainly some systematic oscillation in the primary series explored. Figs. 1 and 2 show the correlograms for Δp and ΔfE respectively for the period under consideration. In both of these the original *unsmoothed* data have been used.

It is important to note that there is a marked trend in the pressure data, and to eliminate this we have dealt with values of pressure departures, Δp (as with the fE data), rather than with the absolute magnitudes p . The oscillations in both correlograms are clear, with a maximum at 26–27 days in each case. These correlograms provide strong support for our original deductions (based, as they were, on simple inspection of graphs), and make it essential for us to repeat Lewis and McIntosh's calculations.

At the outset we must again stress that the pressure data exhibit a marked downward trend (approximately linear), and it is imperative initially to eliminate this before proceeding with any numerical analysis. It appears that Lewis and McIntosh have overlooked this point, and as a result have arrived at quite contrary conclusions. This will be clear from an examination of Table I, in which we present the results of calculations made by us using (i) pressure, p , (ii) pressure departures, Δp , and (iii) fE departures, ΔfE . The nomenclature employed (c , ϕ , σ , etc.) is that used by Lewis and McIntosh.

Without going into details, it can be stated that there is little significant difference between the present results using pressure, p , and those given by Lewis and McIntosh. The slight differences in the values of amplitude c and first serial correlation coefficient r_1 are of no significance and can be ascribed to different ways of deducing the amplitude and phase